

GLOBAL JOURNAL OF ENGINEERING SCIENCE AND RESEARCHES EXPERIMENTAL STUDY ON BEHAVIOUR OF STRENGTHENING STEEL I BEAM WITH FRP SHEET

Ananta Arun Mangle^{*1} & Vishwajeet Kadlagline²

^{*1&2}Department of Civil Engineering, Dr.D.Y.Patil School of Engineering and Technology, pune 412105,
India

ABSTRACT

Fiber reinforced polymer (FRP) sheets are widely used to repair the element of steel structures in rehabilitation. Many research has done in this techniques. Application of this strip to increase the strength of element and it is effective option to increased loads carrying capacity of section and can be repair due to corrosion. FRP strengthened section increase the initial cracking time and reduce the cracks, it also extend the fatigue life. The method used in the research work were flexural tests and the work form of similar studies on the strengthened steel beams. BFRP and GFRP sheet and epoxies of diverse material properties are bonding to the tension, compression and both flanges of I beam section and testing for four point load. In this study we create the model using ANSYS v.12.0. Maximum deflection of beam in ANSYS model and compare to the actual tested beam.

Keywords: BFRP and GFRP sheet, flexure, Displacement, I-beam, steel, strengthening.

I. INTRODUCTION

FRP sheet has been mostly used for strengthening concrete and steel element in structures, and many researcher has been work on these technique. FRP has more value against Anti-corrosion and chemical attacks. Other benefits of FRP sheet it can apply on curved and irregular surfaces of element. Steel plate is difficult to weld on bend and uneven surfaces. This FRP sheets are making by mixing continuous fibers in a polymeric resin matrix which binds the fibers together. In civil industries mostly basalt, glass and carban fibres are used. In this study BFRP and GFRP strips are used.

FRP has more benefits in structural strengthening because it's high strength, anticorrosive material, and high durability. The lost capacity of structural element can be restored easily. FRP sheets strengthened beam extend the fatigue failure for lifetime. And lesser crack size and length if sufficient bond is provided. Now a days strengthening system show the great potential by using carbon fiber and basalt fiber to increase the strength of structural elements. BFRP is more beneficial for strengthening due to economical and cheaply available. CFRP is mostly used to rapair fatigue damage. BFRP is mostly used because of economical and have good chemical and mechanical properties.

The objective of this research was to study the flexural behavior of rolled steel I–beam of appropriate cross section. And compare load carrying capacity of steel I – beams, bonded with BFRP and GFRP sheets and without FRP sheet. And develop Model using ANSYS software to validate the tested beam results.

This study investigates the flexural behavior of the BFRP and GFRP strengthened I beam section and compared with control I beam.

II. EXPERIMENTAL PROGRAM

Raw materials

1. FRP sheets
- GFRP sheet

Glass fibres are cheaply available and economical but sensitive to stress corrosion at high stress and may have problems with relaxation. Tensile strength of gfrp sheet is 875 N/mm^2 , Tensile modulus is 60000 N/mm^2 and strain is 0.0146.

BFRP sheet

Basalt Fiber has good chemical and mechanical properties also the economical performance therefore this is widely used in civil industries. We used bfrp sheet of tensile strength 2100 mpa, tensile modulus of elasticity 105 gpa, weight 300 gsm. and 0.115 mm thickness of sheet.

2. Epoxy Resin, Hardener And Thinner

We used the adhesive to bonding the FRP strips to the steel beam to adhere properly by Araldite AW-106IN/Hardener HV-953IN, it is mixed in proper proportions of 1:1.

3. Steel I beam section

We chosen a beam section MB 100 in which flange width 50 mm and thickness 4mm. total depth is 100 mm and web thickness is 3mm.

Experimental work

For the experimental study steel I-section of depth of beam 100 mm, flange width 50 mm, flange thickness 4 mm and web thickness 3 mm has select for testing sectional dimension shown in Fig.1 and beams was tested using universal testing machine of 1000 KN capacity under four point bending test. We use I-beam to study the flexural failure of I-beam strengthened and without strengthened by FRP sheets. For the chosen beam section there will not be local buckling and vertical stiffness. Basalt fibre sheets (BFS) of tensile modulus of 105 GPa, tensile strength of 2100 MPa, and Glass fiber sheets (GFS) having tensile modulus of 60000 mPa, tensile strength of 875 MPa, is used for strengthening the steel beams of span 700 mm. The locally available epoxy resin “araldite” is used to bonding frp strip to steel section. Before bonding the FRP strip to steel section the portion of bonding is clean and roughened using sand paper to increase bonding strength. Cut The fiber sheets of flange sizes(i.e. 50mmX700mm). Mix The Araldite epoxy resin AW106 and hardener HV953 in proportion 1:1 upto the uniform colour is obtained. Apply the mix resin to beam of constant thickness throught the bonding length and paste the FRP strip immediately care should be taken that there should not presence air pockets. We consider three different parameters for bonding fibre strips. First beam was bonded with fibre strip on bottom flange only while second beam was bonded with fibre strip on both flanges and third beam fibre strip on both flange with anchorage system at ends of tension flange by using steel plate to study the flexural behaviour.

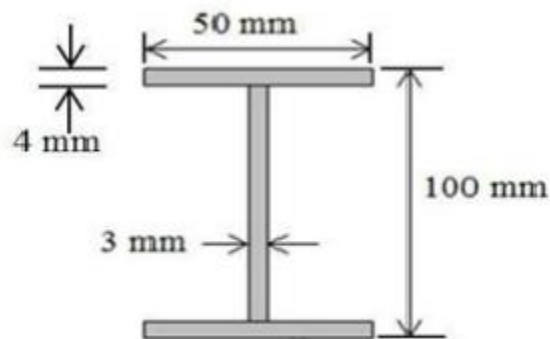

Fig1. Cross sectional details of the I-beam.

Table 1 Details of test beams

Strengthened flange	Type of FRP sheet	designation
Tension flange	BFRP/GFRP	BT1/GT1
Both flange	BFRP/GFRP	BB1/GB1
Both flange with anchorage system at ends.	BFRP/GFRP	BBA/GBA
Control beam		C1

Test setups

The nine specimens were tested with four point loading with 700mm effective span. The sample was placed on two supporting pins a set distance apart. Load specimen continuously without shock. The load applied at constant rate to the breaking point. The load applied at the rate of 0.9- 1.2 MPa/min. The specimens’ fail were mapped and the observations were recorded during the loading and at the time of failure. All the specimens are tested on universal testing machine.

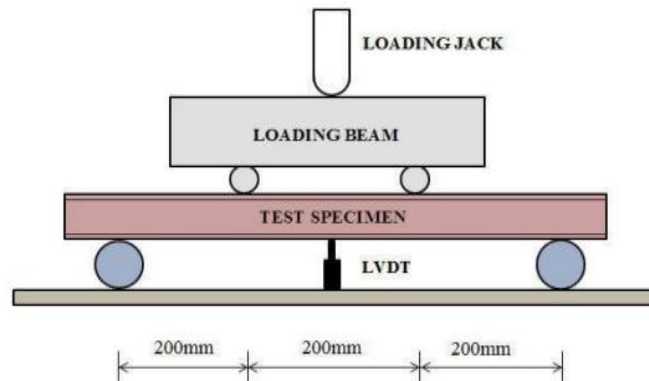

III. RESULTS AND DISCUSSION

During the period of test, beams were visually observed until the visible deflection and the corresponding load was recorded.

A. Control beam result

Load(KN)	Deflection(mm)	Load(KN)	Deflection(mm)
1	0	40	0.28
5	0.01	45	0.31
10	0.05	50	0.515
15	0.12	55	1.05
20	0.19	60	2.5
25	0.2	65	3.95
30	0.24	70	5.28
35	0.27		

B .Tension flange strengthened beam result (BFRP)

Load(KN)	Deflection(mm)	Load(KN)	Deflection(mm)
1	0	40	0.45
5	0	45	0.57
10	0	50	0.65
15	0	55	0.71
20	0.02	60	0.83
25	0.11	65	1.02
30	0.25	70	1.4
35	0.37	73	2.15

D. Both flanges strengthened beam results (BFRP)

Load(KN)	Deflection(mm)	Load(KN)	Deflection(mm)
1	0	40	0.04
5	0	45	0.1
10	0	50	0.18
15	0	55	0.29
20	0	60	0.41
25	0	65	0.5
30	0	70	0.71
35	0	75	1.57
		78	2.7

E. Tension flange strengthened beam result (GFRP)

Load(KN)	Deflection(mm)	Load(KN)	Deflection(mm)
1	0	40	0.42
5	0	45	0.53
10	0	50	0.88
15	0.03	55	1.19
20	0.75	60	1.56
25	0.12	65	2.19
30	0.23	70	3.23
35	0.31	71	

G. Both flanges strengthened beam results (GFRP)

Load(KN)	Deflection(mm)	Load(KN)	Deflection(mm)
1	0	40	0.21
5	0	45	0.38
10	0	50	0.49
15	0	55	0.62
20	0	60	0.77
25	0.04	65	0.89
30	0.09	70	1.25
35	0.16	75	2.10
		78	2.60

IV. CONCLUSION

- The load carrying capacity of the strengthened beam (BFRP bonded at tension flange) is 73 KN and is found to be increased by 13.27% than that of control beam
- Bonding of FRP sheets on the flanges of the steel beam causes increment in elastic behaviour of beam and ultimately gives higher yield point value.
- Using FRP to steel structures enables steel section to restore lost capacity and take additional loads.
- Using FRP to steel sections increases the fatigue life of steel structures and reduces the crack propagation.
- When the steel section is reinforced by FRP, the total load on the structure get increases.
- Using FRP can increase the shear strength & moment capacity of steel section.

V. ACKNOWLEDGMENT

The Authors thankfully acknowledge the staff of civil department of Dr.D.Y.Patil SOET Pune for the support provided to fulfill work

REFERENCES

1. Aniruddh Chandrakant Dubal, Dr. D.N. Shinde, Apurva U. Salunkhe, Mohd. Ali Pendhari “Study Of Flexural Behaviour Of Steel Section Bonded With Basalt Fiber Reinforced Polymer Sheets.”
2. Kambiz Narmashiri I, Mohd Zamin Jumaat and N. H. Ramli Sulong. “Strengthening of Steel I-Beams Using CFRP Strips: An Investigation on CFRP Bond Length.”
3. Dr. N. M. Yossef “Strengthening Steel I-Beams by Welding Steel Plates before or While Loading”
4. Muhammad N.S. Hadi , Jian Song Yuan. “Experimental investigation of composite beams reinforced with GFRP I-beam and steel bars.”
5. Kambiz Narmashiri, N. H. Ramli Sulong and Mohd Zamin Jumaat. “Flexural strengthening of steel I-beams by using CFRP strips.”
6. Mohammed Altaee, Lee Cunningham, Martin Gillie. “CFRP strengthening of steel beam with web openings.”
7. SIKA (2008). SIKA® Product Information Second (usa.sika.com)
8. Steel table by S. Ramamrutham
9. IS 800 – 1984 Indian Standard Code of Practice for General Construction, In Steel.